

MADE IN
ITALY

B0
1988-2018

KARACTER.LL
KARACTER.LLFI

Butler

Karacter^{LL}



- 免撬棍自动拆胎机
- 🇬🇧 **AUTOMATIC TYRE CHANGERS
WITHOUT MOUNTING LEVER**

TYRE CHANGERS



压胎滚轮水平方向移动由具有良好人机交互的操纵手柄来完成，并配备气动锁紧按钮。

The horizontal positioning of the tools is carried out by two ergonomic handles, equipped with pneumatic unlocking button.



A - 压胎滚轮垂直方向运动控制杆
Roller vertical control lever

B - 全自动拆胎头径向运动控制按钮
Roller radial movement control button

C - 鸟头垂直方向运动控制杆
Tool head vertical control lever

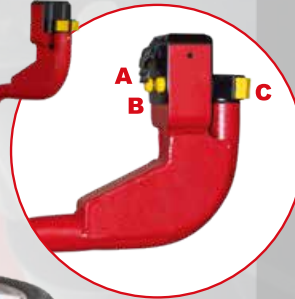

同步移动
Synchro Movement



KARACTER.LLFI
+ PLUS99LL
+G1000A146
+G1000A151

一个简单操作即可实现压胎滚轮的快速，即时，精准的定位。

Rapid and simultaneous bead breaker rollers' positioning in one simple movement

胎唇与钢圈分离
Bead Breaking



轮胎快速拆装
Demounting



BUTLER
PATENT

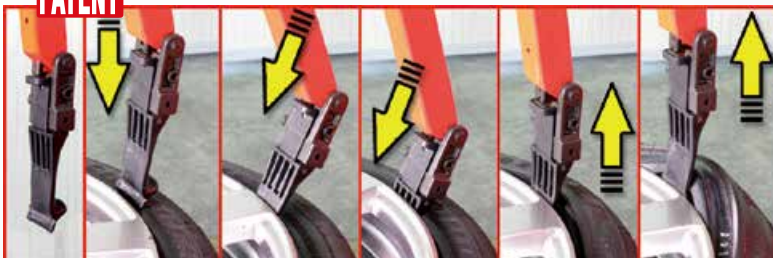

钢化塑制鸟头，免撬棍实现轮胎的无伤剥离。

Tool in scratch-proof material, it removes the bead without damaging the rim and without using levers.

**变频电机
INVE MOTOR**

转盘电机的转速可由技术人员按需精确调节，并配备了调速器用于保护轮胎。逆变器配调节器，用于保护轮胎。

Speed set by the operator, exactly as required. Inverter with governor to protect the tyre.



**BUTLER
PATENT**



G1000A151
辅助压胎铲
Side shovel (Optional)

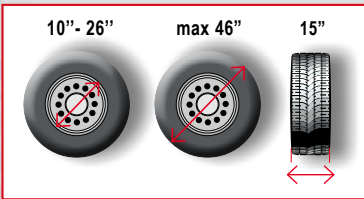

轮胎锁紧装置具备三个可调整的工作高度，适用于更大尺寸的轮胎。
Extra-grip clamping device. Three adjustable working heights.

**标配
STANDARD**



G1000A140
拉动式轮毂胎唇分离组件
Bead pusher with pulling system



G1000A84
锥块保护罩
Cone guard



G1000A81
转盘保护罩
Turntable guard



快速适配锁紧夹具
Quick-fit rim clamping device.



轮胎压力表
Pressure gauge



G1000A86
轮胎底侧拆胎辅助观察镜
Mirror



轮胎定位销延长及保护帽
Extension and guard



中心定位适配器
Centering adaptor

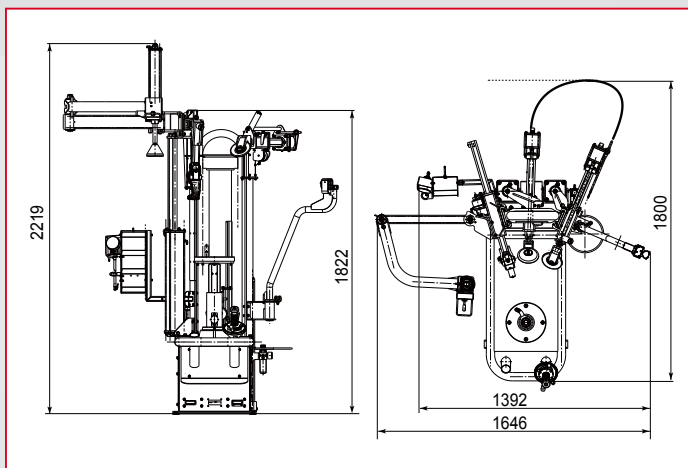

**选配
OPTIONS**



G1000A137
特殊轮胎锁紧装置，适用于无中心孔轮胎，也适用于反装轮胎卡具。也适合换向轮。
Universal flange for closed centre rims. Suitable also for reverse rims.



**轮胎充气装置 F.I. 版本
F.I. VERSION**
新型轮胎充气系统，适合于任何尺寸的轮胎（适用于“F.I”版本）
New powerful tubeless tyre inflation system (for “F.I” version) suitable for any rim diameter.

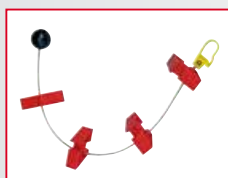

G1000A142
鸟头
Upper tool.

G1000A36



PLUS 99LL
气动轮胎装胎辅助臂
Pneumatic bead depressor.



**G1000A81K (10 套件)
G1000A81K (10 x kit)**
转盘保护罩
Turntable guard



G1000A151



G1000A146
轮胎举升机
Wheel lift.

技术参数	TECHNICAL DATA	
适用轮胎尺寸	Handled wheels from	10"-26"
重量	Weight	315 kg
电压	Voltage	1ph, 200/265v, 50/60Hz
最大轮胎宽度	Max wheel width	15"
最大轮胎直径	Max wheel diam	1168 mm (46")
压胎轮或压胎铲压力（每个臂）	Bead break.pow.(each arm)	12000 N
最大扭矩	Max torque	120 Kgm
电机功率	Rotation Motor	1,5Kw inver.+ 0,75 Kw motor
推荐气源压力	Recommended air supply	8 -10 bar

Butler

路特利举升机（海门）有限公司
Engineering and Marketing S.p.A. a.s.u.
地址：江苏省海门市秀山东路 1388 号
No 1388, East Xiushan Road, Haimen, Jiangsu Province, China.
Ph: 0513-82263361 - www.butler.it - sales@rotaryliftasia.com

A DOVER COMPANY

DBN18U (01)